

# **EZ-Dumper**<sup>®</sup>



## Owner's **Manual** 6 ft. and 8 ft. Dump Inserts

[www.EZ-Dumper.com](http://www.EZ-Dumper.com)



## Table of Contents

Dump Insert Serial Number .....	<b>2</b>
Installation Instructions .....	<b>3</b>
Hold Down Clamp Installation Diagram .....	<b>5</b>
Double Acting Remote Wiring .....	<b>7</b>
Maintenance and Troubleshooting .....	<b>9</b>
Parts List and Identification .....	<b>10</b>
Warranty and Registration Form .....	<b>12</b>
Dump Insert Storing and Vehicle Parking .....	<b>15</b>

## Dump Insert Serial Number

For your convenience, please write down your EZ-Dumper dump insert serial number. The serial number is located on a strip of metal welded to the front (cab side) of the dump insert.

Serial Number: \_\_\_\_\_

### **WARNING**

This User's Manual contains safety information and instructions for your EZ-Dumper dump insert. Before operating or servicing an EZ-Dumper dump insert, you must read, understand and follow the instructions and safety warnings in this manual.

# Installation Instructions with Monarch Pump

**NOTE: DO NOT MOUNT DUMP INSERT TO PLASTIC REMOVABLE BED LINERS**

All EZ-Dumper dump insert units are shipped with an Installation Kit containing (2) Battery Cables, an Installation Manual, (4) ¼" x 3" x 3" Steel Plate Washers, (4) ¼" x 1 ½" x 1 ½" Steel Plate Washers and (4) Steel Clamps. Please check to make sure all items are present before starting installation.

## **THE INSTALLER MUST PROVIDE BOLTS.**

1. Remove factory tailgate from truck.
2. The hydraulic fluid reservoir is shipped full, but may need to be "topped off" with the insert in the "down" position. Before operating the dump insert, make sure the tank is filled to a ½" below the top of the tank.
3. Connect provided battery cables to the hydraulic pump (Monarch brand) as follows:
  - The Red truck battery cable attaches to the stud of the starter solenoid with the black wire.
  - The Black truck battery cable attaches to the motor housing labeled GND.
4. Slide dump insert into truck bed, checking for proper clearance.
  - Rear cross member of dumper frame must not extend beyond the truck bed.
  - **Allow ½" minimum clearance between dump insert pump and front wall of truck bed.**
5. Remove the two (2) shipping straps from the front of the dump insert.
6. Secure power cables. Run the battery cables to the positive and negative terminals of the truck battery.
  - Extreme care should be taken when positioning the cables.
  - Keep cables clear of exhaust system and protect at points of rubbing and sharp edges.

- **DO NOT expose cables below truck frame and prevent from drooping.**

- Keep cables clear of dump insert body rests on the EZ-Dumper insert frame.

7. Push unit forward and position the dump insert properly into the truck bed.

## **CAUTION:**

**TO PREVENT ACCIDENTAL LOWERING OF THE DUMP INSERT, BLOCK UNIT IN RAISED POSITION FOR INSTALLATION AND SERVICING.**

8. Using the remote control, raise the dump insert. Prop is provided for blocking. **DO NOT block under loaded condition.**

9. Four (4) clamps are provided for easy installation of your dump insert. Set the clamps over the sides of the frame at points B and C (refer to the diagram on pages 5 & 6).

**Clamps at location "C" must be positioned over the rear cross member on the EZ-Dumper dump insert sub frame.**

- Clamps at position "C" should be placed as close to the hinge points as possible.
- When possible, use bolt holes provided by front and rear bed bolts.
- If truck bed is welded, holes must be drilled into truck frame or cross member.
- When it is necessary to mount through cross member, reinforce with steel plate washers as illustrated in the installation diagram on pages 5 & 6.
- Use, at minimum, ½" bolts with **lock washers and shake proof nuts.**
- Bolt unit down.

*Installation instructions continue on next page.*

# Installation Instructions with Monarch Pump (continued)

## CAUTION:

**ALWAYS CHECK TO MAKE SURE YOU ARE NOT DRILLING THE FRAME HOLES INTO VEHICLE GAS TANK**

10. Once the unit is bolted down, drill a hole through the clamps and through the dump insert sub-frame, using the hole in the clamp as a guide.

- Bolt the clamp and sub-frame together using proper size bolts, lock washers and nuts (not provided).
- Clamps can also be tack welded to dumper sub-frame.

11. Remove prop rod and cycle several times. Press the "UP" arrow on the hand control to raise the dump bed. Press the "DOWN" arrow on the hand control to lower the dump bed.

**CAUTION: When the dump insert bed is all the way down you will hear it hit the "stops" on the bottom frame. It can not go any lower! DO NOT KEEP PUSHING THE DOWN arrow or the hoist will continue to contract and the link arms could dent the truck bed.**

12. Re-check all bolts to make sure the unit is secure.

**Your EZ-Dumper dump insert is now ready to use.**

## WARNING:

**DO NOT MOUNT DUMP INSERT TO BED SHEET! DUMP INSERT MUST BE BOLTED TO TRUCK FRAME OR CROSS MEMBER!**

**DANGER: PRIOR TO SERVICING THE UNIT, MAKE SURE THE SAFETY PROP IS SECURED. NEVER PLACE ANY PART OF YOUR BODY UNDER THE DUMP INSERT BED WITHOUT THE SAFETY PROP SECURED. DO NOT BLOCK THE DUMP INSERT BED UNDER A LOADED CONDITION. WHEN OPERATING DUMP INSERT BED, KEEP HANDS AND BODY CLEAR OF FRAME AND BED. ALWAYS CHECK BEHIND DUMP INSERT BEFORE DUMPING MATERIAL. DO NOT OPERATE DUMP INSERT WHILE PARKED ON A SLOPE. FAILURE TO COMPLY COULD RESULT IN SEVERE PERSONAL INJURY OR DEATH.**

# Hold Down Clamp Installation Instructions

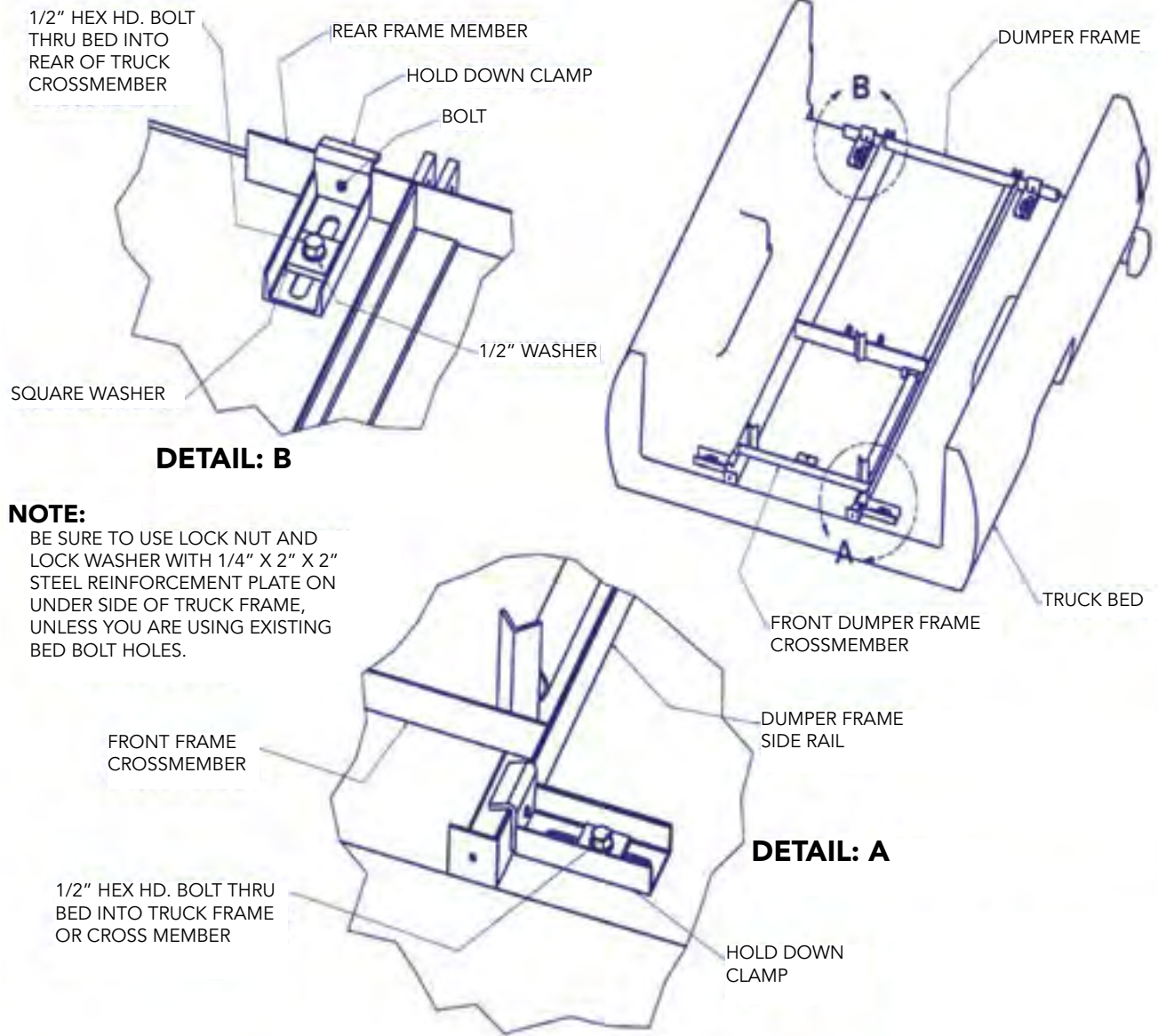

**NOTE:**

BE SURE TO USE LOCK NUT AND LOCK WASHER WITH 1/4" X 2" X 2" STEEL REINFORCEMENT PLATE ON UNDER SIDE OF TRUCK FRAME, UNLESS YOU ARE USING EXISTING BED BOLT HOLES.



# Double Acting Monarch Remote Wiring

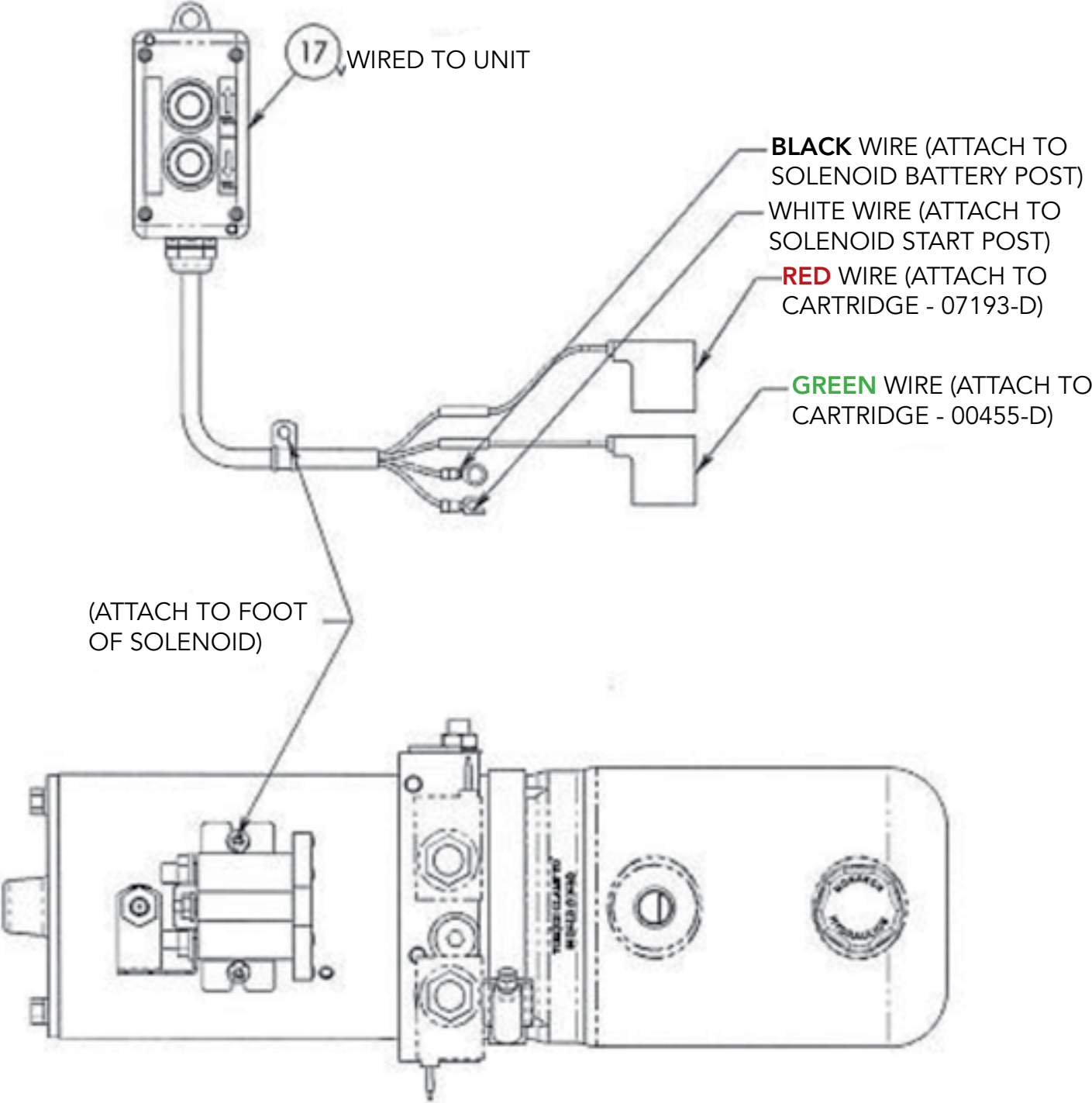

# Double Acting Monarch Pump

ITEM NO.	QTY	PART NO.	DESCRIPTION
1	1	M-3551-0349	PUMP ASSEMBLY
1	1	12379	BASE ASSY,M3551,MOD,STD,MTR/MT
2	1	12171-250	P ASSY,QM,MDLR,DC,BRGSBLD RSV
3	1	00455-D	CARTRIDGE,4-W/2-P,#8 1/2"STEM
4	1	01134	FILTER,SCREEN M-SERIES SUCT.
5	1	01209	TUBE, SUCTION,90 DGR,3/8NPT
6	1	01723-2.00	POPPETASSY, P CMP FL, GPM2.00
7	1	07193-D	CARTRIDGE, 2W/2P, NC, POPPET, 4000
8	4	07818	SCREW,SHC,1/4-20 X 3.0 BLK OX
9	1	13058	TUBE, RETURN, 90DEG, 1/8NPT,M301
10	1	13059	TUBE, RETURN, 90DEG, 1/8NPTF
11	1	06102	RESV/PLASTIC, 4 SDIAX8/H/MT
12	1	07900	CLAMP,HOSE,WORM GEAR,RSVM-SER
13	1	08111	MOTOR,DC,12V4.5'1 TERM
14	1	17757	SWITCH,SOL ACT MTR ST, 12 VDC
15	1	13155	STRAP/MOTOR-SOLENOID CONNECTING
16	2	17071	SCREW/PAN HD,TORX,10-32 X 5/16
17	1	04334DH112-180	CONTROL STATION, WP2 PB,W/180
18	1	03171	PLUG,RESV,BREATHER,3/8 NPT

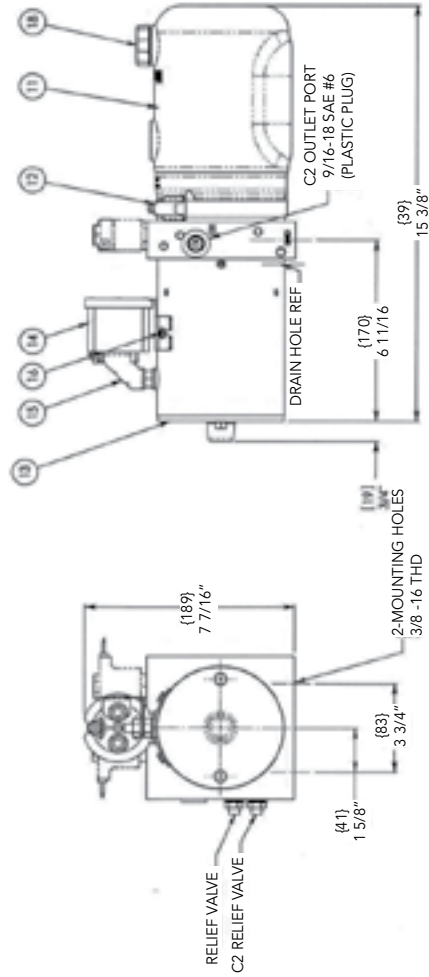
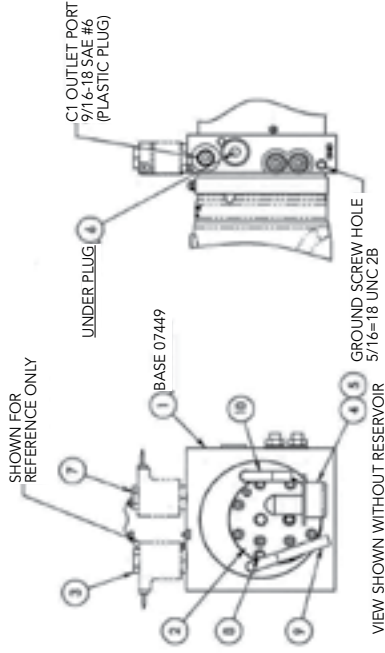
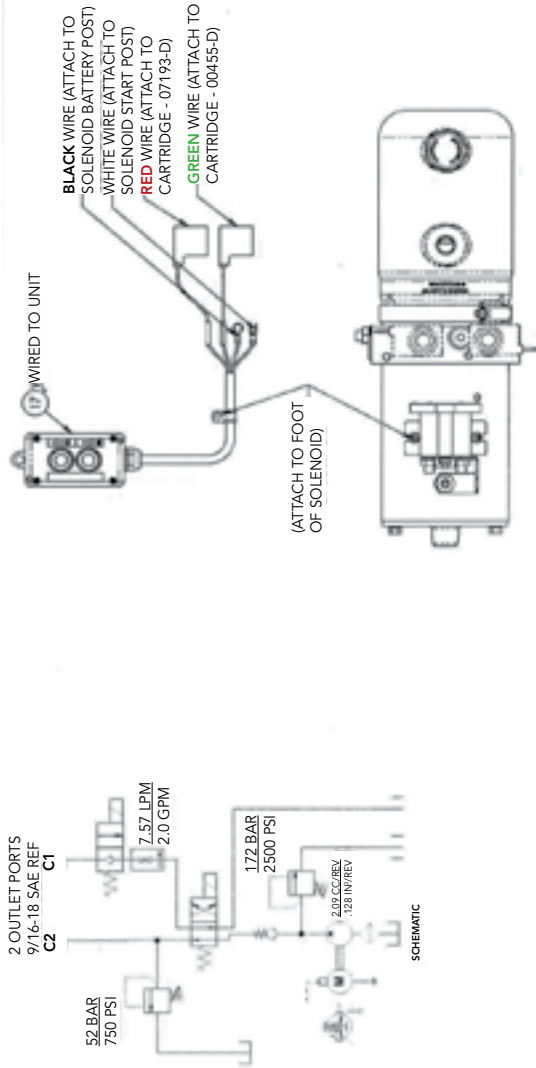



# Maintenance and Troubleshooting

If a malfunction of the power unit occurs, inspect all hydraulic lines and electrical connections, and check for a good ground. Many malfunctions are caused by loose connections.

Check the reservoir for proper fluid level (approximately ½" from top of tank when dumper is down). If fluid must be added, Monarch recommends ATF DEXRON II or equal.

Please keep in mind when servicing this unit that the most common cause of system failure is dirt!

## KEEP SERVICE AREA CLEAN WHEN SERVICING!

- 1. If unit does not operate at all:** Malfunction is due to switch, solenoid, motor, dead battery, corroded terminals, or bad connections at the pump motor package.
- 2. If unit operates slowly and/or with low pressure:** Malfunction is due to a leaking relief valve, clogged filter, worn pump, corroded or bad battery terminals, or hydraulic fluid that is too heavy.
- 3. If unit is unable to hold pressure:** Malfunction is due to a leaking relief valve.

**NOTE:** In most cases a leaking relief valve is caused by dirt. Unscrewing the relief valve and cleaning thoroughly can often correct this.

**NOTE:** The payload carrying capacity of any pickup truck is determined by the GVWR of the cab-chassis, the curb weight of the chassis, and the weight of the body. (An 8 ft. powder coated steel insert weighs approx 787 lbs.)

The pickup truck that carries any EZ-Dumper dump insert must have sufficient carrying capacity and axle ratings for the dump insert. (Gross vehicle weight rating minus curb weight = payload capacity)

To keep your EZ-Dumper dump insert in top condition, follow these simple maintenance procedures:

1. If it squeaks, grease it.
2. Do not operate when low on ATF fluid.
3. Keep service area clean.
4. Do not exceed 5 MPH with the dump insert in the upright position.
5. Avoid sudden stops with dump insert in upright position.



**DANGER**

**SAFETY PROP MUST BE PROPERLY SECURED PRIOR TO SERVICING THE UNIT. NEVER PLACE ANY PART OF YOUR BODY UNDER THE DUMP BED WITHOUT THE SAFETY PROP PROPERLY SECURED. DO NOT BLOCK DUMP BED UNDER LOADED CONDITION. KEEP HANDS AND BODY CLEAR OF DUMP BED WHEN OPERATING. FAILURE TO COMPLY COULD RESULT IN SEVERE PERSONAL INJURY OR DEATH.**

460-90005



**DANGER**

**STAND CLEAR OF REAR OF DUMP BED WHEN DUMPING. FAILURE TO COMPLY CAN RESULT IN SERIOUS INJURY.**

460-90003

# EZ-Dumper Parts List and Identification

- 1 Dumper Body
- 2 Roll Pin
- 3 Cylinder Cross Pin
- 4 Hoist Assembly *(does not include the bottom 2 link support arms) Includes one 1" x 7 1/2" Pin*
- 5 1" x 9" Pin *(2 used on link support arms)*
- 6 Link Support Arms
- 7 4" x 9 1/2" Stroke Double Acting Hydraulic Cylinder
- 8 Double Acting Hydraulic Hose Assembly
- 9 Double Acting Monarch Hydraulic Pump With 1 Quart Reservoir
- 13 Bottom Frame
- 15 Hold Down Clamp
- 16 Safety Prop
- 17 1" x 7 1/2" Pin
- 19 Start Motor Solenoid 12 Volt
- 20 Double Acting Monarch Remote
- 23 Hose Fitting - Swivel
- 24 Hose Fitting - Swivel
- 30 Serial Number Plate

## Miscellaneous Parts

- Seal Kit for current Double Acting Cylinder
- Black Cable Assembly 4 Gauge
- Red Cable Assembly 4 Gauge
- Steel Cab Protector
- Tarp Kit
- Tail Gate Pin Assembly
- Tail Gate Chain
- Tapered 2-Way Replacement Tail Gate for Insert
- 20" Side Rail and Tailgate Extension

# EZ-Dumper Parts List and Identification

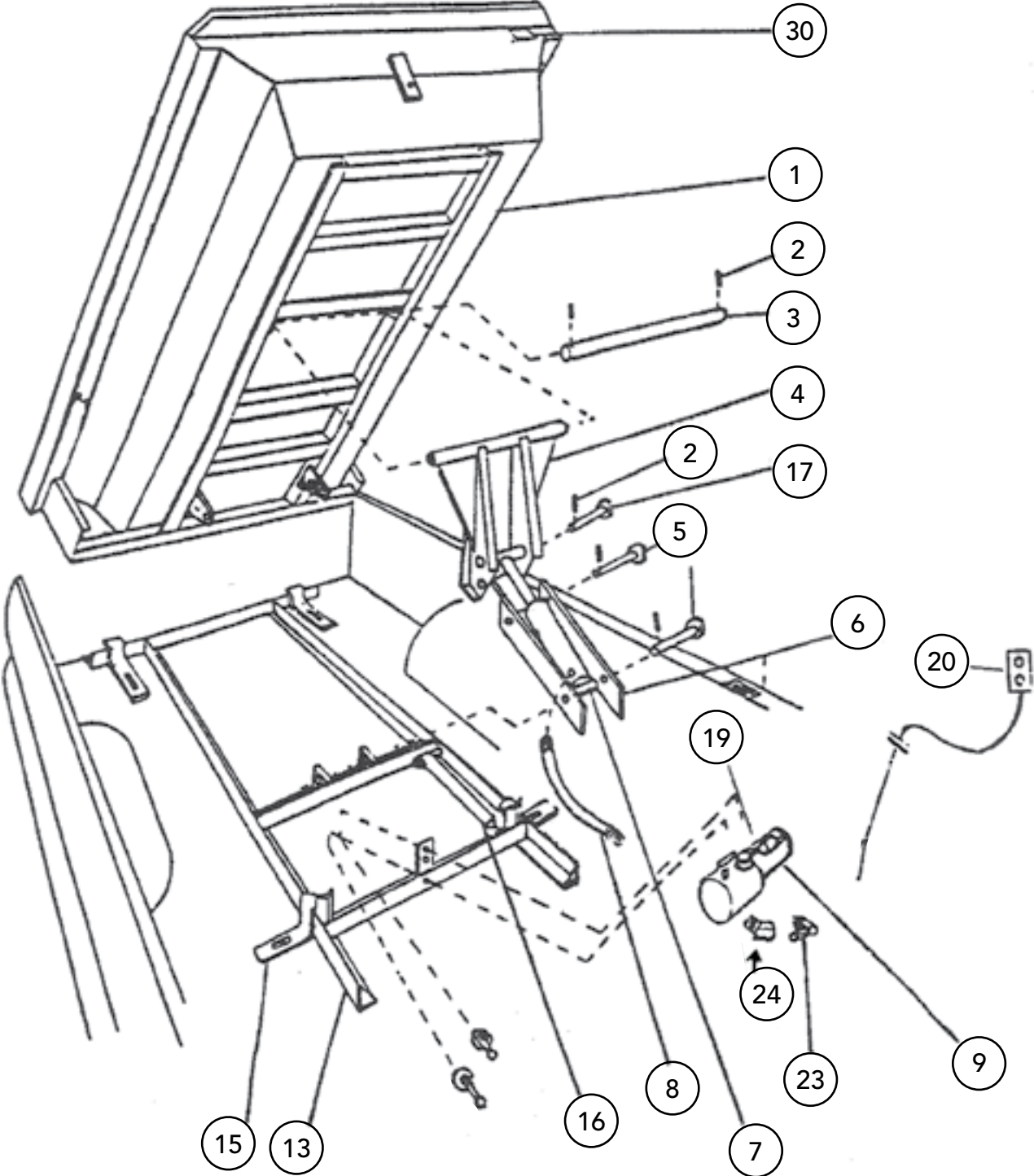



## Manufacturers **Warranty**

EZ-Dumper warrants each new dump insert to the original purchaser to be free from defects in material and workmanship under normal use and service for a period of two (2) years from the date of original sale.

EZ-Dumper, hereinafter referred to as "Manufacturer" warrants each new dump insert to the original purchaser to be free from defects in material and workmanship under normal use and service for a period of two years from the date the product is originally invoiced to the end-user or on the date the new product was first put into service, whichever comes first. You must submit a completed "Warranty Registration" form to Manufacturer within 15 days of this date or subsequent warranty claims will not be honored.

The Manufacturer's liability and obligation is limited to repair or at the Manufacturer's option, replacement of the product provided the purchaser returns the claimed defective product to the Manufacturer or an authorized dealer, with transportation charge prepaid, and examination by the Manufacturer discloses the product is defective.

Manufacturer makes no warranty with respect to hydraulic pumps, cylinders, or other accessories not manufactured by the Manufacturer, as these items are warranted by the respective manufacturer of those items. (Hydraulic Pumps are manufactured by Bucher/Monarch Hydraulics and have a 1 year manufacturer's warranty, Cylinders are manufactured by Beiler Hydraulics and have a 1 year manufacturer's warranty)

This warranty does not cover said product which has been repaired or altered without the Manufacturer's authorization that would affect the stability, reliability, safety, or performance of the product.

This warranty does not cover damage or product failure, caused by accident, misuse, negligence, tampering, overloading, improperly attached, or improperly maintained.

Manufacturer will only warrant its paint from defects as a result of improper preparation and application. The Manufacturer is held harmless for any injury or death caused by the misuse of this product.

This warranty is expressly in lieu of all other warranties and representations, expressed or implied, and all other obligations or liabilities on the part of EZ-Dumper.



# Warranty Registration

Please complete all information below. You are responsible for filling out this warranty registration form and sending it to EZ-Dumper. Warranty coverage begins on the date the product is originally invoiced to the end-user, or on the date the new product was first put into service, whichever comes first. **YOU MUST SUBMIT A COMPLETED "WARRANTY REGISTRATION" FORM TO EZ-DUMPER WITHIN 15 DAYS OF THIS DATE OR SUBSEQUENT WARRANTY CLAIMS WILL NOT BE HONORED.** Receipt of this warranty registration form by EZ-Dumper establishes the date on which the warranty coverage begins and validates the warranty.

### Registration Information

Company Name \_\_\_\_\_

Contact Name \_\_\_\_\_

Address \_\_\_\_\_

City \_\_\_\_\_ State \_\_\_\_\_ Zip \_\_\_\_\_

Phone (\_\_\_\_) \_\_\_\_\_ Fax (\_\_\_\_) \_\_\_\_\_

Email Address \_\_\_\_\_

Serial # \_\_\_\_\_ Model No. \_\_\_\_\_

Dealer/Distributor \_\_\_\_\_

In-Service/Warranty Start Date \_\_\_\_\_ Salesperson \_\_\_\_\_

Type of business? (check one)

Landscaper  General Contractor  Nursery  Golf Course  City Municipality  University

Other \_\_\_\_\_

\_\_\_\_\_  
Dealer/Distributor Signature

\_\_\_\_\_  
Date

\_\_\_\_\_  
End-User Signature

\_\_\_\_\_  
Date

**MAIL TO: EZ-DUMPER, P.O. BOX 70, WAYNESBORO, PA 17268 OR FAX TO: 717-762-1966**

WARRANTY FORM:  
REMOVE AND SUBMIT TO  
EZ-DUMPER  
P.O. Box 70 • Waynesboro, PA 17268

# Vehicle Parking

EZ-DUMPER INSERT

## WARNING:

IF YOU PARK YOUR TRUCK FACING DOWNHILL, BE ADVISED THAT WATER CAN ACCUMULATE IN THE TRUCK BED: THIS SUBMERGING YOUR HYDRAULIC PUMP UNIT UNDER WATER. (See Drawing Below.)

TRUCK BED

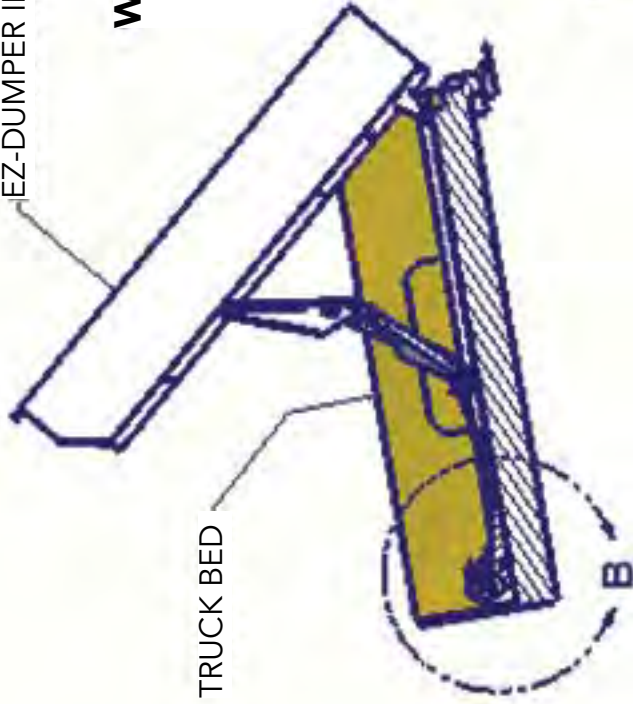

WATER LEVEL

FRONT OF TRUCK BED

PUMP MOTOR

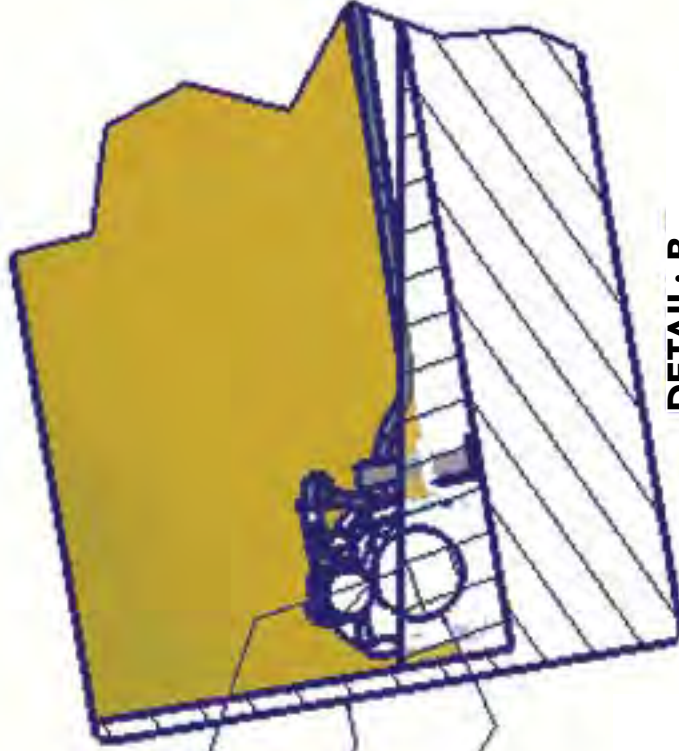

**DETAIL: B**

## **THIS WILL VOID YOUR WARRANTY!**

SUBMERGING YOUR PUMP WILL RUIN THE PUMP MOTOR. ALWAYS STORE OR PARK YOUR TRUCK AND DUMPER INSERT FACING UP-HILL; SO THAT ACCUMULATED RAIN WATER CAN DRAIN FROM BED OF TRUCK. THIS SAME WARNING APPLIES TO STACKED AND STORED INSERTS ON DEALER LOTS.



6806 Anthony Highway • P.O. Box 70 • Waynesboro, PA 17268  
Tel: 866-967-DUMP • [www.EZ-Dumper.com](http://www.EZ-Dumper.com)

This document is non-contractual. Constant improvement and engineering progress make it necessary that we reserve the right to make specification, equipment, and price changes without notice.